



*Paving Intelligence into
Safety, Security & Mobility*

XCam-p™

Presence Detection Video Sensor



Citilog's XCam-p is a real-time video-sensor enclosed in a rugged elegant housing for vehicle presence detection at intersections and on ramps.

The XCam-p video-sensor is designed to replace or expand upon in-road magnetic loop detectors with a vehicle presence detection solution featuring an advanced video-based sensor. Ideal at

intersections and on-ramps, XCam-p eliminates constraints imposed by embedded loops. Power and communications infrastructure are also not an issue since XCam-p provides built-in low power consumption and wireless communications.

XCam-p components (particularly the CMOS sensor) have been specifically designed to ensure durability of the sensor while optimizing performance of the video-detection algorithm. The XCam-p's detection algorithm is flexible and adaptable to changing environmental conditions (night or day, sun or rain) to maximize traffic monitoring capabilities.

The XCam-p is a low cost sensor that makes the most of existing infrastructure and its components resulting in a quick return on investment and an excellent cost/benefit ratio. The XCam-p video sensor allows a more cost effective option to replace loop-based detection. It also enables low-cost seamless expansion of vehicle presence detection capabilities and monitoring reach for intersections and on ramps.

System setup and modification of detection zones are performed within a few minutes, with a friendly graphical user interface (GUI) via a laptop computer.

Detection zones are easily associated with loop detector outputs for a direct loop replacement.

Fail-safe functionality allow for true 24/7 operation.

The XCam-p communicates with any traffic controller through a communications board (XCom) for direct loop replacement or through more advanced communications protocols.

The XCam-p can be installed up to a distance of 300m from the XCom, which is typically installed in the traffic controller cabinet. A wireless module enables a wireless connection of several XCam-p video sensors.



KEY CAPABILITIES

- Accurate vehicle presence detection at intersections.
- Direct loop replacement.
- Low power consumption and wireless communications for easy deployment and integration.
- Video streaming for intersection monitoring.
- Seamless communication with traffic controllers and integration into existing urban traffic management systems.
- Improves road safety and mobility thus reducing environmental impacts from traffic congestion and delays.

KEY BENEFITS

- Low cost and seamless deployment of presence sensors.
- Fast ROI for above-ground detection compared to traditional road-embedded sensors.
- Reduce the negative economic, social and environmental impact from traffic congestion.
- Improve infrastructure efficiency.



The XCam-p can provide video streaming permitting remote monitoring of intersections and monitoring via the Traffic Management Center. Configuration or maintenance operations can also be performed remotely for greater efficiency and a lower cost of operation and maintenance.

The XCam-p is delivered with a mounting bracket, extension pole and connection block. This allows the XCam-p to be installed in the field without opening the video sensor housing, thus extending its life and avoiding troubleshooting in the field. Its capabilities go beyond typical requirements of video-based presence sensors to ensure durability.

The extension pole can be adjusted in length and mounted either horizontally or vertically to fit the physical requirements of any site.

The XCam-p provides a cost-effective, easy-to-install and field-proven solution for vehicle presence detection at signal-controlled intersections.

Technical Specifications

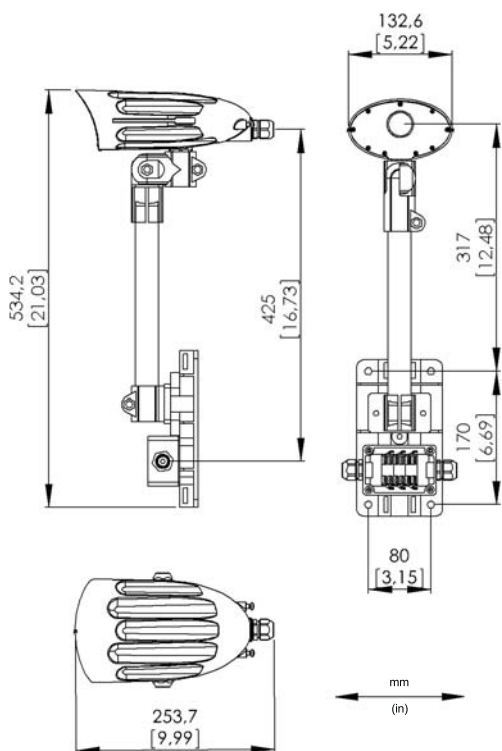

Sensor

- 1/4" VGA CMOS sensor.
- Minimum illumination 0.04 lux. @ f/1.2.
- Anti-blooming, zero smearing.
- Signal to Noise ratio: >50dB.

Housing

- IP67 Injection molded polycarbonate housing.
- Sun shield for hot climate and direct sun exposure.
- Size: 132 x 254 x 124 mm.

Hardware

- Power Supply: +12/24V AC/DC.
- Power consumption: < 3W.
- -34°C / +74°C.
- Humidity: 0 to 95% RH, non condensing.
- Weight: 600 g.

Communications

- Wireless module (GPRS, ISM).
- Output to XCom: Ethernet or RS485.

XCom communications board

- Communications to a traffic controller.
 - 24 open collectors.
 - Ethernet.
 - Serial.
- DIN-rail mountable.
- Size: 175 x 107 x 26 mm.
- Connection to PC: USB, Ethernet.



DETECTION HIGHLIGHTS

- High performance trajectory and tracking-based vehicle presence detection.
- High efficiency algorithm with comprehensive filters for all weather and lighting conditions.
- Easy setup, configuration and maintenance.
- Video streaming capability.

APPLICATIONS

- Embedded loop replacement.
- Presence detection at stop bar.
- Advanced / mid-block detection.
- Ramp metering.



www.citilog.com

NORTH AMERICA

2 Bala Plaza, Suite 300
Bala Cynwyd, PA 19004 - USA
Tél: +1 (215) 609-4945
Fax: +1 (484) 873-2292
citilogusa@citilog.com

EUROPE, MEA & AFRICA

19/21, rue du 8 mai 1945
94110 Arcueil - France
Tél: +33 1 41 24 34 54
Fax: +33 1 41 24 34 99
citilog@citilog.com

SPAIN, PORTUGAL & SOUTH AMERICA

C/.Marina Baixa 3, Esc.1 Pta.2
E46015 Valencia - Spain
Tél: +34 667 659 063
Fax: +33 1 41 24 34 99
espana@citilog.com

ASIA PACIFIC

35/F Central Plaza
18 Harbour Road
Wanchai Hong Kong
Tél: +852 2593 1500
Fax: +852 2593 1222
citilog@citilog.com

Latest Hardware specifications available upon request