

This product has been designed to be highly versatile for a host of global traffic applications. The 307 Doppler radar operates in the 24GHz band. Its very compact size belies the outstanding detection performance offered by this entry level radar.

- Vehicle radar detection for multiple applications
- Technically advanced detection platform
- Modern, compact stand-alone detector
- Cost-effective solution

INTERSECTION CONTROL

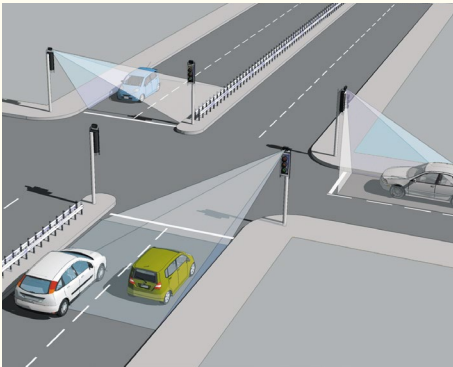

- Compact unit for ease of installation
- Dual lane monitoring
- Approach or bi-directional detection
- 24Vac/dc and 230Vac supply options
- User adjustable parameters via DIP and rotary switches

SIGN ACTIVATION



- RS422 speed measurement outputs
- User adjustable parameters via optional RS422 interface
- Solar powered options (<1W at 12Vdc)
- 4kph-120kph adjustable low speed threshold

TEMPORARY TRAFFIC CONTROL

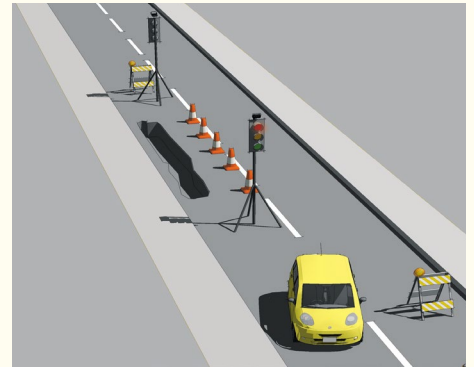

- 12Vdc supply
- User selectable low speed threshold typically 4kph or 8kph via DIP switch
- IP65 rated
- Robust polycarbonate enclosure
- Nudge facility

DIMENSIONS:

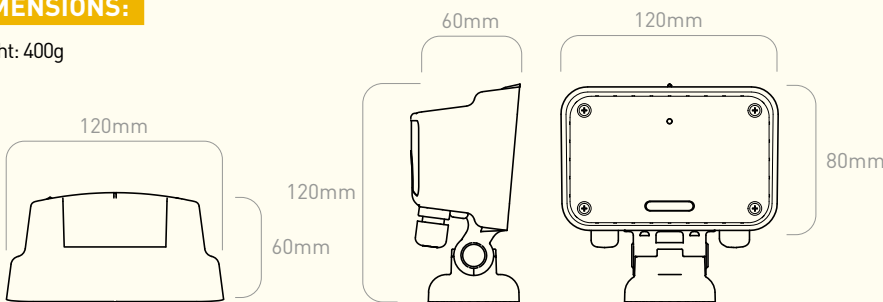

Weight: 400g



SPECIFICATIONS

Technology	CW Doppler Radar
Detect Output	Opto-isolator/Relay/RS422
Range/Zone	Up to 150m (user selectable)
Mounting Height	2-5m nominal
Housing Material	Black polycarbonate
Sealing	IP65
Operating Temp	-20°C to +60°C
Power	0.8W - 1.0W @ 24Vac
Approved to:	ETSI EN 301 489 BS EN 50293 ETSI EN 300 440 BS EN 60950

307 TESTING PROCESS

	TEST EQUIPMENT:	SATURN™	
	PRODUCT TEST:	307 308 330	
	TEST FUNCTION:	<ul style="list-style-type: none"> • Simulated speed range 4-200 kph • Signal size and direction control • Optimisation of frequency signals • Test cycle time 7 minutes 	<small>SATURN was designed and developed by AGD Systems</small>



LIFETIME PRODUCT TRACEABILITY

There are clearly defined pass and fail criteria at all stages within the Saturn test process. The test results in association with the product build revision are recorded on a product serial number basis. The full suite of test measurements is instantly sent to the dedicated product database within the AGD secure server facility, providing full traceability during the product lifetime.

The AGD Certified symbol is your mark of assured performance.

AGD Systems Limited

White Lion House, Gloucester Road
Staverton, Cheltenham
Gloucestershire, GL51 0TF, UK

T: +44 (0)1452 854212
E: sales@agd-systems.com
W: agd-systems.com

Saturn™ is a bespoke set of test equipment designed and developed by AGD Systems. It is dedicated to the testing of the 307 detector range and 100% of these units manufactured at AGD are Certified by Saturn.

The key test functions performed by Saturn to Certify the premium performance of your Intelligent Detection System are:

- Simulated speed range from 4-200kph
- Optimisation of frequency signals
- Transmitted radar power and frequency measurement
- Radar signal to noise level measurement
- Verification of DIP and rotary switch parameter operation
- >15hr hour burn-in
- Test cycle time of 7 minutes

The AGD designed vehicle radar target simulator which forms part of the Saturn test equipment enables reliable simulation of a range of vehicle speeds in quick succession during the test process. This gives full control of simulated targets' signal size, speed and direction.

Optimisation of frequency signals on Saturn ensures full compatibility with different country requirements within the 24GHz radar operating band.

All DIP switch parameters and detect output LED operation are verified during the test cycle.

100%



Saturn is a bespoke set of test equipment designed and developed by AGD Systems dedicated to the testing of the 307 detector range. 100% of these units manufactured at AGD are Certified by Saturn

